



CITY OF PINOLE

DEVELOPMENT SERVICES DEPARTMENT

2131 Pear Street
Pinole, CA 94564

Phone: (510) 724-8912
FAX: (510) 724-4921

WINDOW REPLACEMENT REQUIREMENTS

Permit Requirements:

1. The replacement or addition of new windows, sliding glass doors or skylights requires a building permit. Obtain and fill out a building permit application and owner-builder form if applicable.
2. Provide a fully dimensioned floor plan showing the size and use of all rooms and areas within the space where the windows are being replaced/ altered and include all door, window and stair locations. Include all bathrooms and tub/shower locations. Identify each door or window opening as new or existing. Clearly identify on plans the location of any **added** windows or doors. Clearly identify all sizes of windows.
3. If windows or door sizes are being altered, provide existing and proposed elevations for all affected sides of structure. Provide framing specifications and details.
4. Provide window/door schedule indicating the size and type of windows/doors being installed.
5. Windows shall have a maximum u-value of **1.25** must be **National Fenestration Rating Council (NFRC)** rated and labeled.

New Installations:

2016 California Residential Code (CRC)-Emergency Rescue and Escape Openings:

Basements, habitable attics and sleeping rooms shall have at least one exterior emergency escape and rescue opening. Such openings shall **1)** open directly into public way, yard or court that opens to a public way, **2)** have a minimum net clear opening area of 5.7square feet (5.0 square feet for grade-floor level openings) with minimum net clear dimensions of 24" opening height and 20" width and **3)** have a clear opening height of not more than 44" above floor. Note a 24" by 20" window does not meet egress requirements, please see chart on next page. **2016 CRC, Section R310**

Safety Glazing Requirements:

Windows installed within 24" of doors, 18" of walking surfaces, and within stairways are required to be tempered. Windows within tub or shower enclosures that are positioned less than 60" above drain must also be tempered.

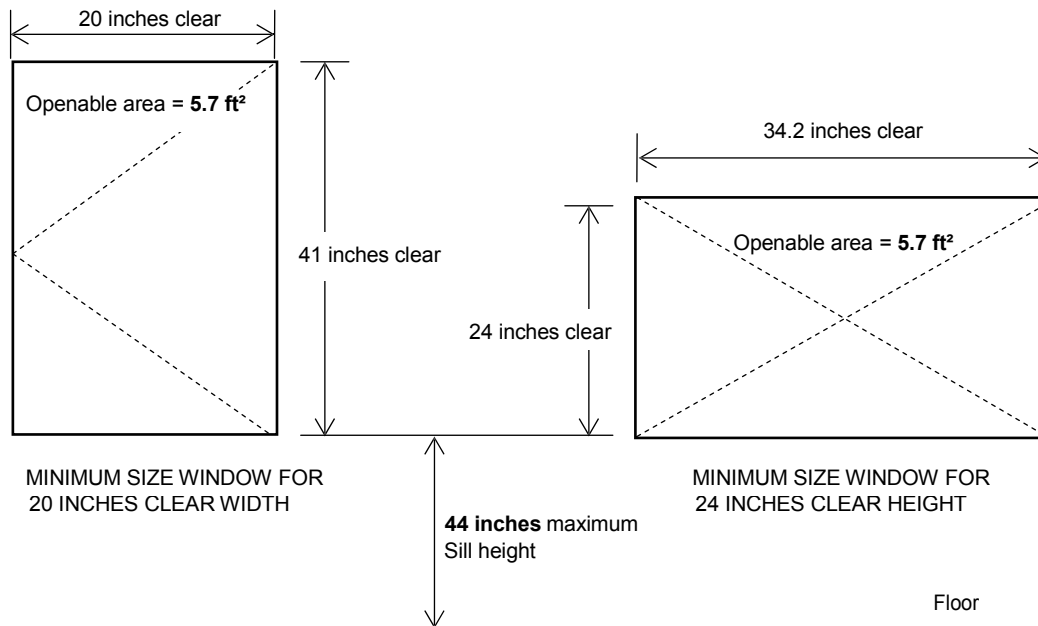

Minimum Width/Height Requirements for Emergency Escape and Rescue Windows (inches)

Width	20	20.5	21.5	21.5	22	22.5	23	23.5	24	24.5	25	25.5	26	26.5	27
Height	41	40	39.1	38.2	37.3	36.5	35.7	34.9	34.2	33.5	32.8	32.2	31.6	31	30.4
Width	27.5	28	28.5	29	29.5	30	30.5	31	31.5	32	32.5	33	33.5	34	34.2
Height	29.8	29.3	28.8	28.3	27.8	27.4	26.9	26.5	26.1	25.7	25.3	24.9	24.5	24.1	24

Bars, grills, grates, covers and screens shall comply with Title 24, Part 12, Chapter 12-3 and CRC Section R310.4.

Retrofit Window Installations:

A retrofit window replaces the glazing and the sash, but leaves the existing frame in place. ***Retrofit windows do not need to meet exact dimensional requirement for egress (sill height and openable area), but they need to meet the minimum energy code requirements and not reduce egress capacity or make the building less safe for the occupants. All efforts must be made to install the largest unit as possible.*** Minor reductions in the clear opening dimensions of replacement doors and windows that result from the use of different materials shall be allowed. **CRC AJ 401.2**

Please Note: This handout is for reference only. There may be additional conditions or requirements that could affect your project.

Please call the Development Services Department office at (510) 724-8912 for more information.